

Please check the examination details below before entering your candidate information

Candidate surname

Other names

Pearson Edexcel
International
Advanced Level

Centre Number

--	--	--	--	--

Candidate Number

--	--	--	--	--

Thursday 7 May 2020

Morning (Time: 1 hour 30 minutes)

Paper Reference **WBI11/01**

Biology

International Advanced Subsidiary / Advanced Level

Unit 1: Molecules, Diet, Transport and Health

You must have:

Scientific calculator, ruler, HB pencil

Total Marks

--

Instructions

- Use **black** ink or ball-point pen.
- **Fill in the boxes** at the top of this page with your name, centre number and candidate number.
- Answer **all** questions.
- Answer the questions in the spaces provided – *there may be more space than you need.*
- **Show all your working in calculations and include units where appropriate.**

Information

- The total mark for this paper is 80.
- The marks for **each** question are shown in brackets – *use this as a guide as to how much time to spend on each question.*
- In questions marked with an **asterisk (*)**, marks will be awarded for your ability to structure your answer logically, showing how the points that you make are related or follow on from each other where appropriate.

Advice

- Read each question carefully before you start to answer it.
- Try to answer every question.
- Check your answers if you have time at the end.

Turn over ►

P62456A

©2020 Pearson Education Ltd.

1/1/1



Pearson

DO NOT WRITE IN THIS AREA

DO NOT WRITE IN THIS AREA

DO NOT WRITE IN THIS AREA

BLANK PAGE



Answer ALL questions.

Write your answers in the spaces provided.

Some questions must be answered with a cross in a box . If you change your mind about an answer, put a line through the box and then mark your new answer with a cross .

- 1 The primary structure of a protein determines its secondary structure and its three-dimensional structure.

(a) Read through the following account of the primary structure of a protein.

(5)

Complete the account by writing the most appropriate word or words on the dotted lines.

The primary structure of a protein is the specific sequence of amino acids joined together by bonds.

These bonds are formed between the group of one amino acid and the group of an adjacent amino acid by a reaction.

These bonds are formed during the stage of protein synthesis called

- (b) The table describes the types of bond that hold the secondary and the three-dimensional structures together.

Which type of bonding is true for each structure?

(2)

Structure	Hydrogen bonds only	Ionic bonds only	Both hydrogen and ionic bonds	Neither of these bonds
secondary structure	<input type="checkbox"/>	<input type="checkbox"/>	<input type="checkbox"/>	<input type="checkbox"/>
three-dimensional structure	<input type="checkbox"/>	<input type="checkbox"/>	<input type="checkbox"/>	<input type="checkbox"/>

(Total for Question 1 = 7 marks)



- 2 Most Bengal tigers are orange with black stripes but there is a very small number of Bengal tigers that are white with black stripes.

The photograph shows a white Bengal tiger with black stripes.





(Source: Caroline Wilcox)

White tiger offspring are produced by two Bengal tigers that each carry at least one recessive allele for a gene affecting coat colour.

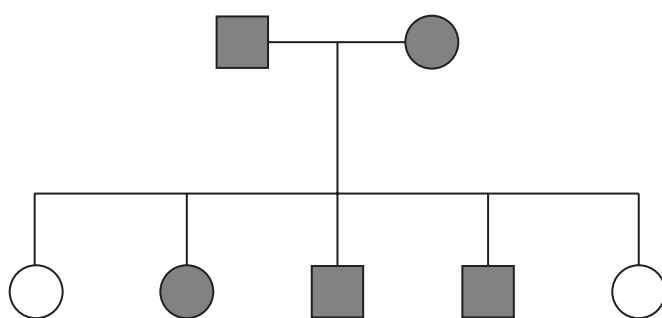
The pedigree diagram shows the phenotypes in one family of tigers, bred in captivity.



Key

-  female orange tiger
-  female white tiger
-  male orange tiger
-  male white tiger

- (a) The phenotype is affected by the genotype.

State what is meant by the term **genotype**.

(1)

.....

.....

.....



(b) State the probability that the next tiger born to these two parents will be female. (1)

(c) Determine the expected phenotypic ratio of orange tigers to white tigers born to the parents shown in this pedigree diagram.

Use a genetic diagram to support your answer. (3)

Answer

(d) The incidence of white tigers in the wild is 1 in 10 000 Bengal tigers.

There are approximately 6000 Bengal tigers in captivity, 200 of which are white.

Calculate the incidence of white tigers in captivity. (1)

Answer

(Total for Question 2 = 6 marks)



3 The cardiac cycle is the sequence of events that occurs when the heart beats.

A typical cardiac cycle takes 0.86 seconds.

(a) The diagram illustrates the cardiac cycle.

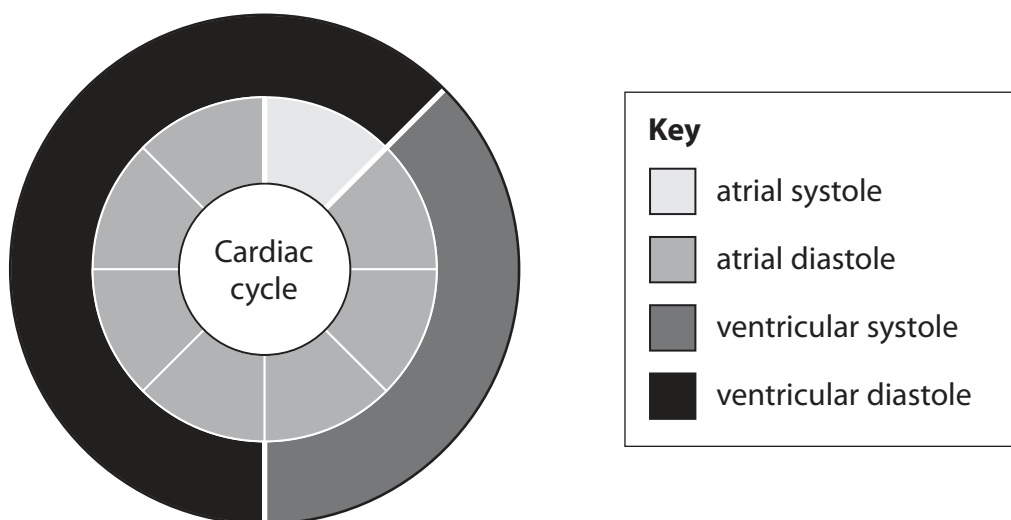

(i) Which row of the table describes the atria and ventricles during atrial systole?

(1)

	Atria	Ventricles
<input type="checkbox"/> A	contracted	contracted
<input type="checkbox"/> B	contracted	relaxed
<input type="checkbox"/> C	relaxed	contracted
<input type="checkbox"/> D	relaxed	relaxed

(ii) Explain why there is a delay of 0.01 seconds between atrial systole and ventricular systole.

(2)

.....

.....

.....

.....

.....

.....

.....



(iii) Using the information in the diagram, calculate the duration of ventricular systole in milliseconds.

Express your answer in standard form.

(2)

Answer ms

(iv) State what proportion of the cardiac cycle is spent in ventricular diastole.

(1)

.....

.....

(b) A typical cardiac cycle takes 0.86 seconds.

During exercise, the heart rate increases and the duration of the cardiac cycle decreases.

Calculate the increase in heart rate if the cardiac cycle decreases by 0.4 seconds.

(3)

Answer beats per minute

(Total for Question 3 = 9 marks)

DO NOT WRITE IN THIS AREA

DO NOT WRITE IN THIS AREA

DO NOT WRITE IN THIS AREA



- 4 The polynucleotide DNA is composed of mononucleotides linked together.
Two polynucleotides form a DNA molecule.
(a) The diagram shows part of a DNA molecule.

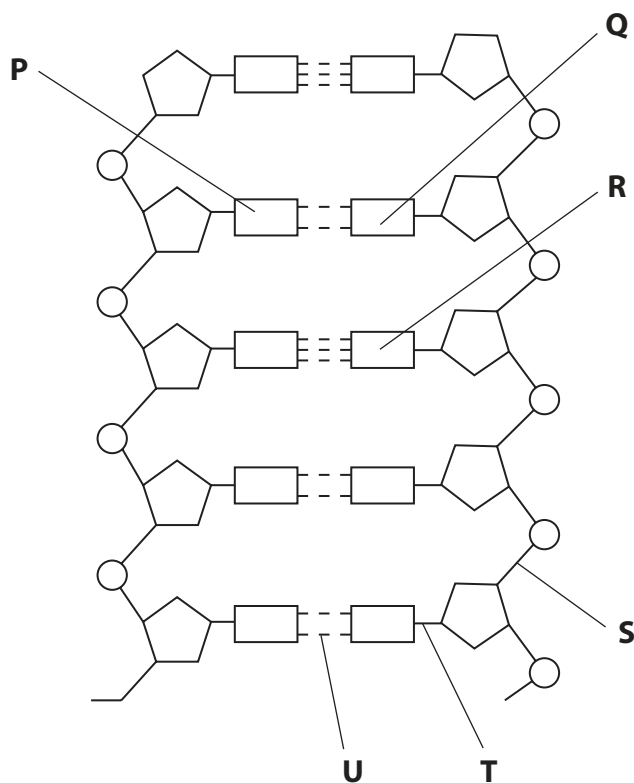

- (i) Draw a circle around **one** mononucleotide that includes the base labelled **R**.

(1)



(ii) Which row of the table identifies the bonds labelled **S**, **T** and **U**?

(1)

	S	T	U
<input type="checkbox"/> A	hydrogen	phosphodiester	covalent
<input type="checkbox"/> B	hydrogen	covalent	phosphodiester
<input type="checkbox"/> C	phosphodiester	hydrogen	covalent
<input type="checkbox"/> D	phosphodiester	covalent	hydrogen

(iii) The base labelled **P** is adenine.

Which is the base labelled **Q**?

(1)

- A** cytosine
- B** guanine
- C** thymine
- D** uracil

DO NOT WRITE IN THIS AREA

DO NOT WRITE IN THIS AREA

DO NOT WRITE IN THIS AREA



- (b) Meselson and Stahl carried out experiments that provided evidence for the semi-conservative replication of DNA.

Heavy nitrogen (N^{15}) and light nitrogen (N^{14}) were used in these experiments.

The flow chart summarises part of one experiment performed by Meselson and Stahl.

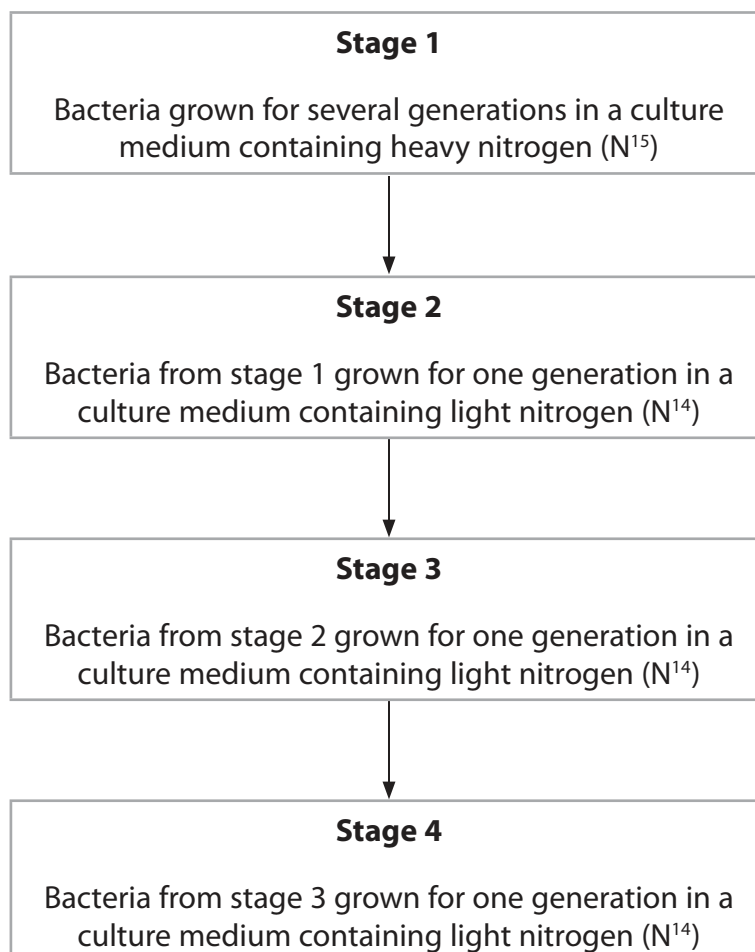

After each stage, a sample of DNA was taken from the bacteria and the DNA molecules separated using a density gradient in a tube.

The heavier DNA molecules form bands lower down the gradient than the lighter DNA molecules.

The height of each band is proportional to the percentage of DNA molecules in the sample.



(i) Complete the diagram to show the results of this experiment.

Use the dotted lines to help you to position the bands on the diagram.

The first one has been done for you.

(5)

DNA sample taken
after stage 1

DNA sample taken
after stage 2

DNA sample taken
after stage 3

DNA sample taken
after stage 4

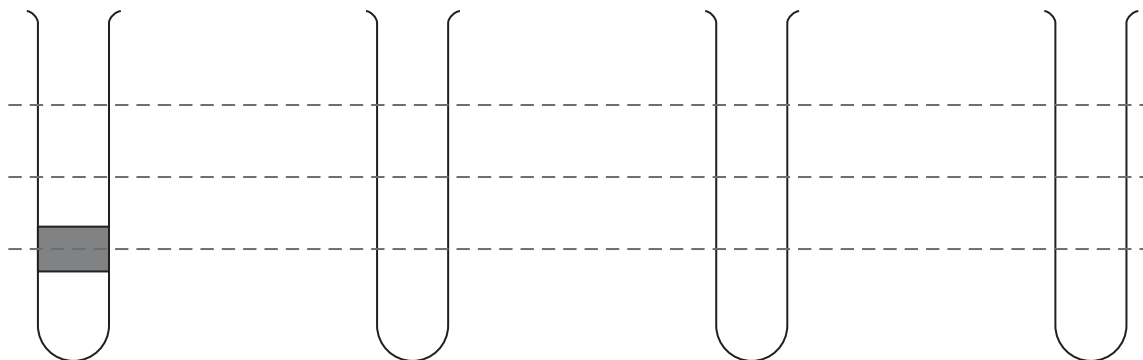

DO NOT WRITE IN THIS AREA

DO NOT WRITE IN THIS AREA

DO NOT WRITE IN THIS AREA



(ii) The experiments of Meselson and Stahl disproved the dispersive theory of DNA replication.

The diagram shows the expected results if the dispersive theory was correct.

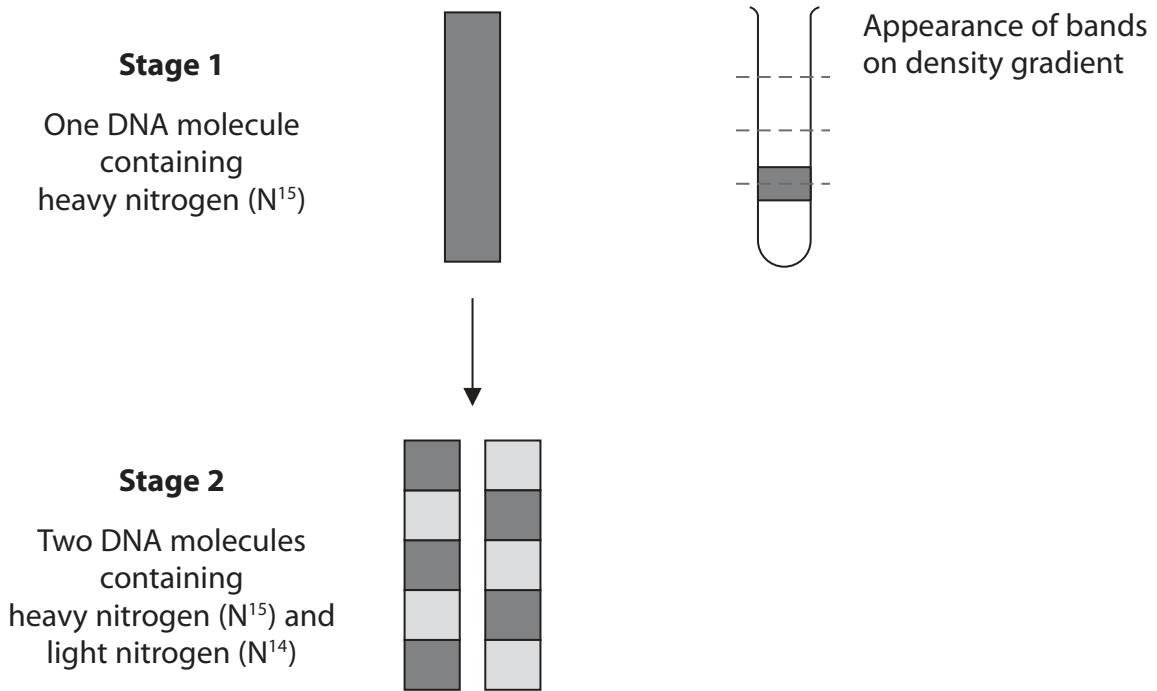

Which diagram would show the bands of DNA molecules on the density gradient at stage 2, if the dispersive theory was correct?

(1)

A

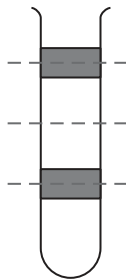

B

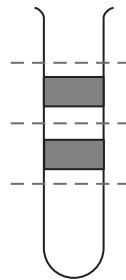

C

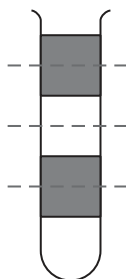

D

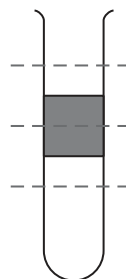

(Total for Question 4 = 9 marks)



5 Obesity increases the risk of cardiovascular disease (CVD).

One way to reduce obesity is to lose weight by changing eating habits.

(a) Name **two** obesity indicators used by scientists.

(1)

1

2

(b) Glucomannan is a dietary supplement claimed to aid weight loss.

Glucomannan is a branched polysaccharide similar in structure to amylopectin.

(i) Which glycosidic bonds are responsible for the branching in glucomannan?

(1)

A 1-4 only

B 1-6 only

C both 1-4 and 1-6

D neither 1-4 nor 1-6

(ii) In the presence of water, glucomannan swells to form a semi-solid gel.

The diagram shows a stomach with glucomannan present and a stomach without glucomannan.

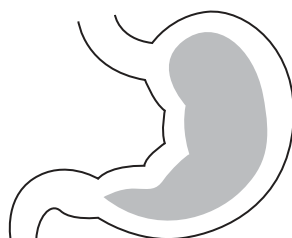
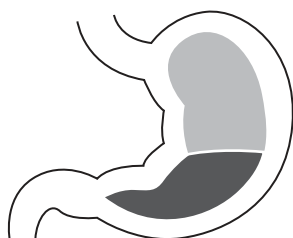

Key

 food

 glucomannan

Suggest how glucomannan aids weight loss.

(1)

.....

.....

.....



(iii) If glucomannan could be digested it would cause a gain in weight.

Explain why glucomannan could cause a gain in weight.

(2)

.....

.....

.....

.....

.....

.....

DO NOT WRITE IN THIS AREA

DO NOT WRITE IN THIS AREA

DO NOT WRITE IN THIS AREA



(c) A study compared weight loss in two groups of women.

One group of women had a low-fat diet and the other group of women had a very low-carbohydrate diet.

(i) The table shows the results of this study.

Number of weeks on the diet	Mean body mass of the group of women / kg	
	Group on the low-fat diet	Group on the very low-carbohydrate diet
0	92.5	91.1
2	90.6	88.3
4	89.9	87.5
6	89.0	85.6
8	88.8	84.5
10	88.3	84.1
12	88.2	83.0

Many studies claim that a low-carbohydrate diet can result in two to three times as much weight loss as a low-fat diet.

Determine the extent to which this study supports this claim.

(3)

.....

.....

.....

.....

.....

.....

.....

.....

.....

.....

.....



(ii) Very low-carbohydrate diets may increase cardiovascular risk factors.

Give **two** factors, other than weight loss, that should have been monitored in this study.

(2)

1

2

(Total for Question 5 = 10 marks)

DO NOT WRITE IN THIS AREA

DO NOT WRITE IN THIS AREA

DO NOT WRITE IN THIS AREA



DO NOT WRITE IN THIS AREA

DO NOT WRITE IN THIS AREA

DO NOT WRITE IN THIS AREA

BLANK PAGE



P 6 2 4 5 6 A 0 1 7 3 2

6 A gene contains the genetic code for the sequence of amino acids in a polypeptide chain.

The table shows the genetic codes found in DNA.

Genetic code	Amino acid	Genetic code	Amino acid	Genetic code	Amino acid	Genetic code	Amino acid
AAA AAG	Lysine	CAA CAG	Glutamine	GAA GAG	Glutamic acid	TAC TAT	Tyrosine
AAC AAT	Asparagine	CAT CAC	Histidine	GAC GAT	Aspartate	TCA TCC TCG TCT	Serine
ACA ACC ACG ACT	Threonine	CCA CCC CCG CCT	Proline	GCA GCC GCG GCT	Alanine	TGG	Tryptophan
AGA AGG	Arginine	CGA CGC CGG CGT	Arginine	GGA GGC GGG GGT	Glycine	TGC TGT	Cysteine
AGC AGT	Serine	CTA CTC CTG CTT	Leucine	GTA GTC GTG GTT	Valine	TTA TTG	Leucine
ATA ATC ATT	Isoleucine					TTC TTT	Phenylalanine
ATG	Methionine						

The genetic codes TAA, TAG and TGA are stop codons, that do not code for amino acids.



DO NOT WRITE IN THIS AREA

DO NOT WRITE IN THIS AREA

DO NOT WRITE IN THIS AREA

*(a) Explain the nature of the genetic code.

Use information in the table to support your answer.

(6)

Area with horizontal dotted lines for writing the answer.



P 6 2 4 5 6 A 0 1 9 3 2

(b) The diagram shows the sequence of nucleotide bases in part of a DNA template (antisense) strand.

Number	1	2	3	4	5	6	7	8	9	10	11	12	13	14	15	16	17	18
Base	A	T	G	G	C	T	T	G	C	C	C	G	A	T	C	C	T	A

(i) Give the sequence of amino acids that is coded for by these bases.

(1)

(ii) Explain the possible effects on a protein if there is a substitution mutation in the 9th base in this DNA strand.

Use information in the table to support your answer.

(5)

(Total for Question 6 = 12 marks)



DO NOT WRITE IN THIS AREA

DO NOT WRITE IN THIS AREA

DO NOT WRITE IN THIS AREA

BLANK PAGE



P 6 2 4 5 6 A 0 2 1 3 2

7 Warfarin is used in the treatment of cardiovascular disease.

Warfarin inhibits the synthesis of prothrombin.

(a) Describe the role of prothrombin in the blood clotting process.

(3)

.....

.....

.....

.....

.....

.....

.....

.....

.....

.....

(b) Which type of treatment is warfarin?

(1)

- A anticoagulant
- B antihypertensive
- C platelet inhibitor
- D statin



(c) Reduced vitamin K is needed for the synthesis of prothrombin.

An enzyme, vitamin K epoxide reductase (VKOR), converts vitamin K to reduced vitamin K.

The diagram shows this conversion.



(i) The diagrams show the structures of warfarin and vitamin K.

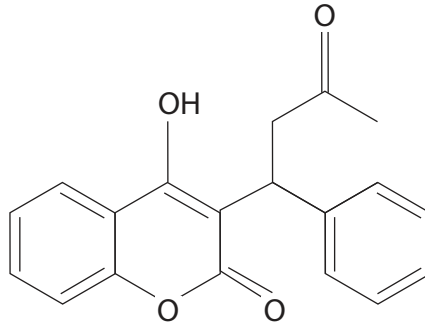

Warfarin

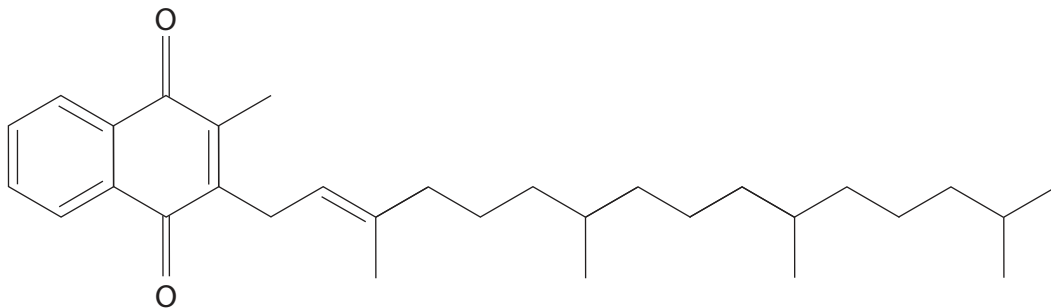

Vitamin K

Using the information in the diagrams, suggest why warfarin inhibits the synthesis of prothrombin.

(2)

.....

.....

.....

.....

.....

.....



(ii) Suggest why people taking warfarin have to avoid eating foods that contain a high concentration of vitamin K.

(2)

.....

.....

.....

.....

.....

.....

DO NOT WRITE IN THIS AREA

DO NOT WRITE IN THIS AREA

DO NOT WRITE IN THIS AREA



DO NOT WRITE IN THIS AREA

DO NOT WRITE IN THIS AREA

DO NOT WRITE IN THIS AREA

(d) Other drugs are available that work in a similar way to warfarin.

The diagram shows one study to compare the effect of warfarin with drug X.

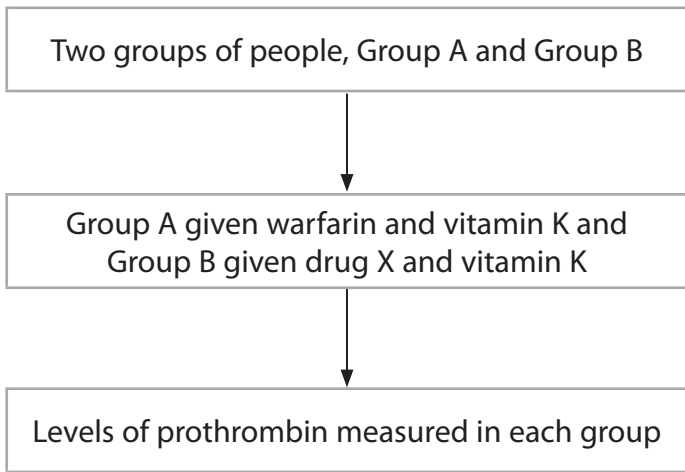

Explain how this study should be designed so that the effectiveness of these two drugs can be compared.

(4)

.....

.....

.....

.....

.....

.....

.....

.....

.....

.....

.....

.....

.....

.....

.....

.....

.....

.....

.....

.....

.....

.....

.....

.....

(Total for Question 7 = 12 marks)



8 Low-density lipoproteins (LDLs) transport lipids around the body in the blood.

Low-density lipoproteins can result in the development of atherosclerosis.

They can be absorbed into the endothelial cells lining arteries and broken down by free radicals.

The diagram shows a low-density lipoprotein containing cholesterol.

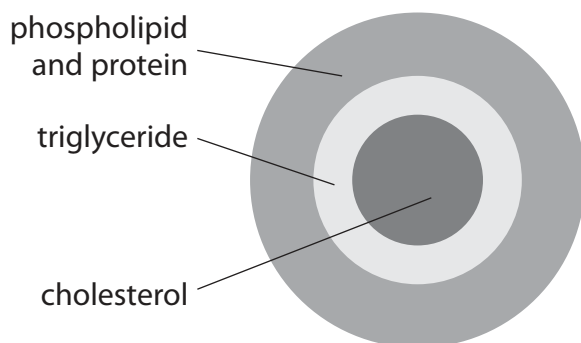

(a) Compare and contrast the structure of a triglyceride and a phospholipid.

(3)

.....

.....

.....

.....

.....

.....

.....

.....

.....

.....



(b) Explain why the properties of LDLs enable cholesterol to be transported in the blood.

(3)

.....

.....

.....

.....

.....

.....

.....

.....

.....

.....

(c) The diameters of LDLs range from 19 nm to 24 nm.

The table shows some information about LDLs.

Diameter of LDL / nm	Volume of LDL / nm ³	Volume of cholesterol / nm ³	Ratio of LDL volume to cholesterol volume
19	3590	523	7:1
24		523	

(i) Complete the table by calculating the volume of LDL and the ratio of LDL volume to cholesterol volume.

Use the formula $v = \frac{4}{3}\pi r^3$

(3)



*(ii) The graph shows the relationship between LDLs, high-density lipoproteins (HDLs) and the risk of CVD.

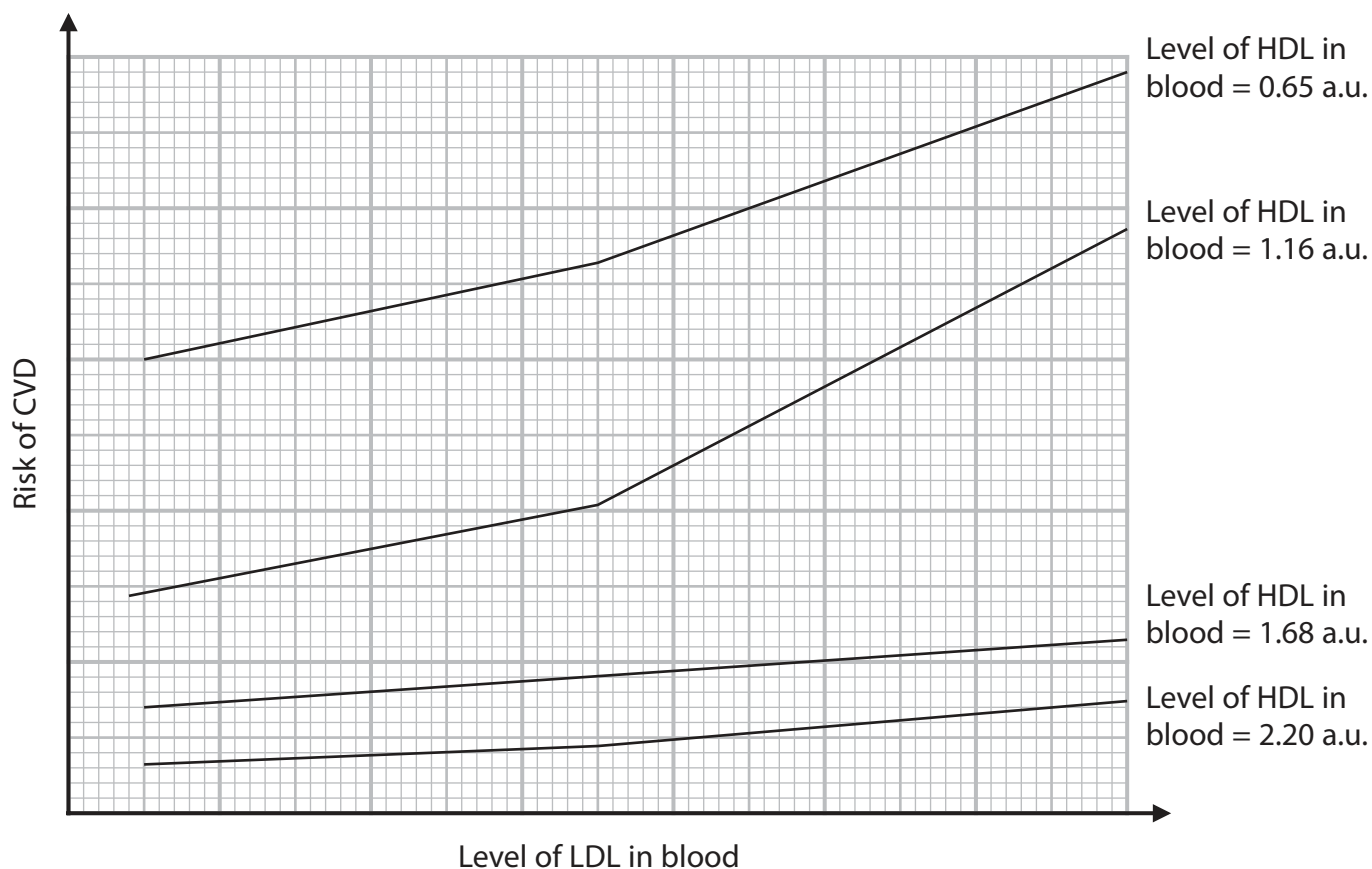

Explain why measuring only the level of LDL in the blood is **not** a reliable predictor of CVD.

Use the graph, all the information in this question and your own knowledge to support your answer.

(6)

.....

.....

.....

.....

.....

.....

.....

.....

.....

.....

DO NOT WRITE IN THIS AREA

DO NOT WRITE IN THIS AREA

DO NOT WRITE IN THIS AREA



DO NOT WRITE IN THIS AREA

DO NOT WRITE IN THIS AREA

DO NOT WRITE IN THIS AREA

Handwriting practice area with ten horizontal dotted lines.

(Total for Question 8 = 15 marks)

TOTAL FOR PAPER = 80 MARKS



P 6 2 4 5 6 A 0 2 9 3 2

DO NOT WRITE IN THIS AREA

DO NOT WRITE IN THIS AREA

DO NOT WRITE IN THIS AREA

BLANK PAGE



DO NOT WRITE IN THIS AREA

DO NOT WRITE IN THIS AREA

DO NOT WRITE IN THIS AREA

BLANK PAGE



P 6 2 4 5 6 A 0 3 1 3 2

DO NOT WRITE IN THIS AREA

DO NOT WRITE IN THIS AREA

DO NOT WRITE IN THIS AREA

BLANK PAGE

